

VersiCell®

Sub-Surface
Drainage Modules



Enhancing Our Environment

VersiCell® sub-surface drainage modules enhance our environment by providing an effective alternative to gravel aggregates used in conventional drainage systems.



VersiCell®

VersiCell® offers architects and developers greater design flexibility and has a wide range of applications in the landscape, building and construction industries.

VersiCell® is a high-strength, lightweight, interlocking 100% recycled plastic structural module used for sub-surface drainage. The open surface design and high internal void volume result in highly efficient drainage.

In a green roof application, VersiCell® provides a drainage cavity and an additional protection layer for the waterproof membrane(s). It eliminates the need for a gravel course.

VersiCell® modules are easily interlocked in the same plane (a) or at right angles (b) to one another. The modules may also be butted together without interlocking.

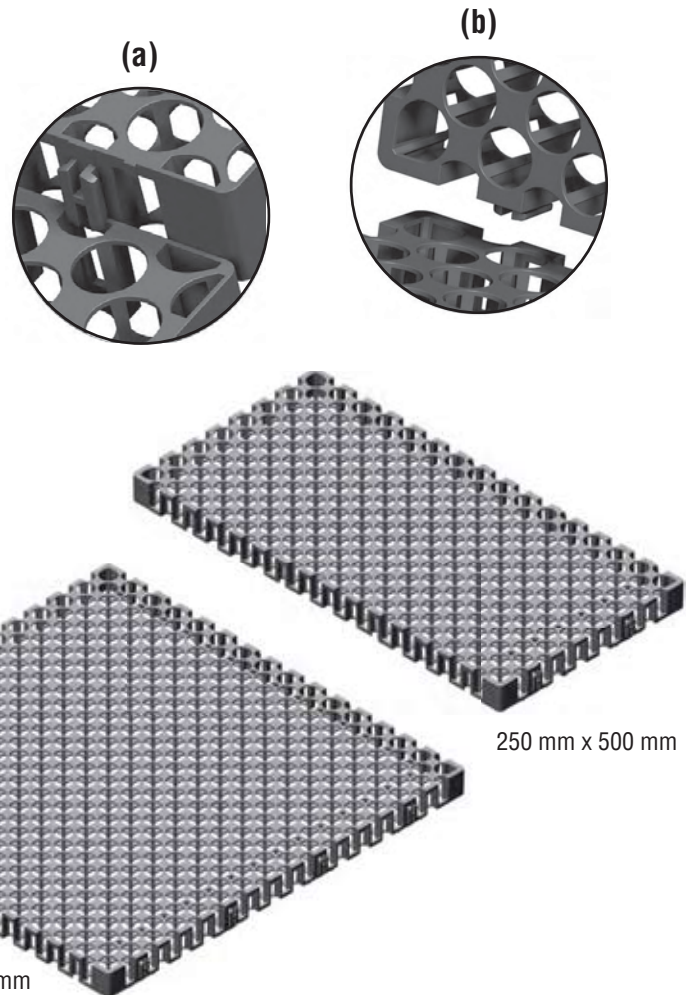

Applications

Typical areas of applications include:

- Green roof and landscaped decks
- Paved areas and roadways
- Sports fields
- Retaining/basement walls
- Pond filtration
- Bridge abutments
- Tunnels and landfills
- Golf courses



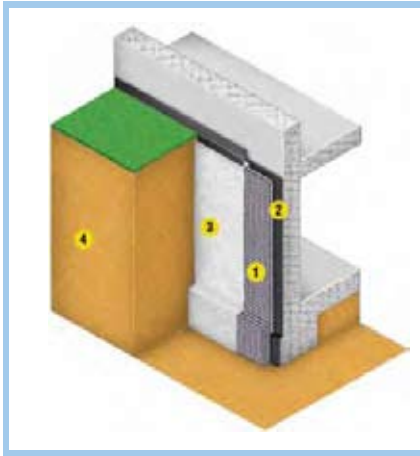

- 1. VersiCell®
- 2. Waterproof membrane
- 3. Geotextile
- 4. Soil

Basement Wall

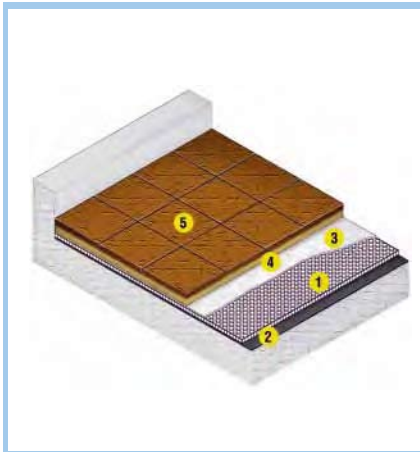

- 1. VersiCell®
- 2. Waterproof membrane
- 3. Geotextile
- 4. Sand
- 5. Pavers

Plaza Deck

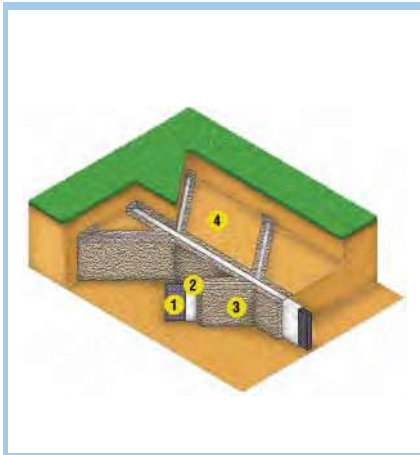

- 1. VersiCell®
- 2. Geotextile
- 3. Coarse Sand
- 4. Soil

Sports Field

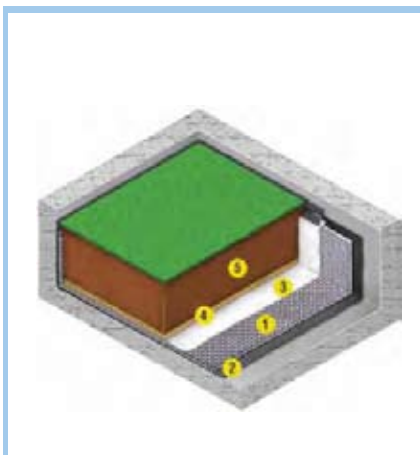

- 1. VersiCell®
- 2. Waterproof membrane
- 3. Geotextile
- 4. Coarse sand
- 5. Planting soil

Landscape Deck



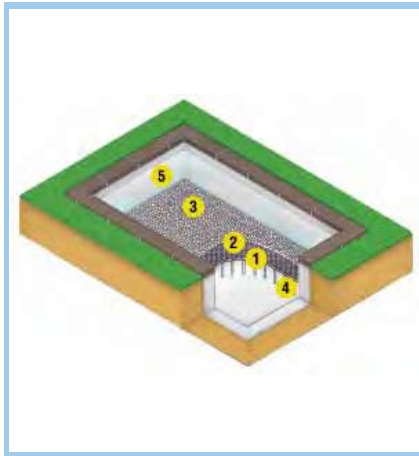

1. VersiCell®
2. Geomesh
3. Pebbles
4. Pipe support
5. Waterproof membrane

Pond Filtration



Advantages

Design Flexibility

Greater design flexibility as the modules may be interlocked in one plane or at right angles to form continuous large panels, conduits and tanks.

Easy Installation

Large easy-to-join modules or pre-assembled panels allow rapid installation and minimise on-site disruption.

Lightweight and High Strength

Honeycomb design results in lightweight, high compressive strength.

Durable

The modules are resistant to biological attack and a wide range of chemicals.

Efficient

High surface and internal void volume results in efficient drainage. Narrow profile enables greater soil depth to be utilised in planter beds allowing a wider variety of landscape plants.

Environmentally Friendly

VersiCell® is manufactured from high strength 100% recycled plastics.

Specifications

Modular Size:

VersiCell® 3050 500 mm L x 500 mm W x 30 mm H

VersiCell® 3025 500 mm L x 250 mm W x 30 mm H

VersiCell® 2050 500 mm L x 500 mm W x 20 mm H

Weight:

30 mm < 3 kg/m²

20 mm < 2 kg/m²

Material: Polypropylene

Colour: Black

Compressive Strength: >100 t/m²

Discharge Capacity @ 1% gradient:

30 mm >16.5 l/m.s

20 mm >13.0 l/m.s

Surface Void Area: >62%

Internal Void Area: >95%

Biological/Chemical Resistance: Unaffected by moulds and algae. Resistant to oils, acids, alkalis and bitumen.

Service Temperature: -20° C to 120° C

VersiCell® is also known as Nordrain® and Nordrain® V. International patents pending

Note: The information provided in this brochure is based on current knowledge and experience and does not infer any legally binding assurance or warranty, expressed or implied. Intending purchasers should verify whether any changes to specifications or applications or otherwise have been made since this literature was issued. The products in this brochure are manufactured using specified recycled plastics under detailed quality control standards and procedures. Factors including source of raw material and manufacturing processes may impact slightly on the strength of the modules.



Singapore: +65 6356 2800
Australia: +61 2 9648 2073

www.elmich.com

Distributed by: